

SURFACE FIXED DIGITAL GATE LOCK, SINGLE-SIDED



SPECIFICATION SHEET

BDGSW

- A marine grade Digital Gatelock with many unique features.
- Auto-latching – close the gate and the latchbolt latches into the gate frame. To open the gate – enter the code and turn the handle.
- No power needed – High quality digital keypads ensure long lasting durability.
- Latchbolt is adjustable in length for precise fitting on site.



PRODUCT DETAILS

Product code:	Description:
BDGSWL	Left handed, single sided (keypad one side, handle other side)
BDGSWR	Right handed, single sided (keypad one side, handle other side)

Latchbolt: Adjustable, moves 20mm (¾"). Auto-latching when gate closes.

Keep box included.
No power needed.

Right hand lock shown



BDGW keep (supplied with lock)

INSTALLATION

- Position Z bracket on edge of the gate in a suitable position (use the keep to ensure there is sufficient clearance) and mark 3 holes for the outside keypad fixing screws (top and bottom central holes) and the spindle (directly above bottom central hole). Drill 2x 8mm (¼") holes for the screws and a 12mm (½") hole for the spindle. Fix Z bracket to the gate using 3 screws supplied.
- Cut the 2 x M5 screws supplied to length to suit (gate thickness minus 20mm (13/16")) and cut spindle to suit (gate thickness plus 70mm (2 ¾") for double sided locks and gate thickness plus 90mm (3 ½") for single sided locks).
- Fit the outside keypad and Z bracket using M5 screws. Insert spindle and ensure it can move freely within the gate. If it cannot move freely you may need to enlarge the hole.
- Position lock on to the spindle and fix to the angle bracket using the stainless steel cover plate and the 2 x M8 countersunk screws. Screw on locking bolt, this may be adjusted as per point 6.
- Mark the keep position on the gate post and fix using 4 screws supplied. Test and adjust accordingly.
- ADJUSTMENT** To adjust latchbolt length rotate the bolt as required for length and orientation, then insert 3mm long arm hex key (supplied) into end of bolt and turn clockwise to lock in place.
- MAINTENANCE** Lubricate with light oil periodically.

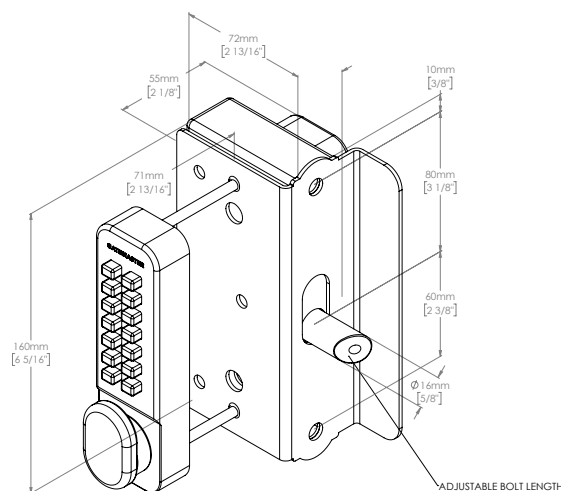

GATEMASTER

VISIT GATEMASTERLOCKS.COM FOR MORE INFORMATION



SURFACE FIXED DIGITAL GATE LOCK



SPECIFICATION SHEET

BDGSW

LOCK CODE:

C _____

TO CHANGE THE CODE

1. Check the original code is working on the keypad.
2. For the outside keypad, skip to point 3. For the inside keypad, to remove the keypad off the lock, ensure the Z bracket is removed and then screw the 2 M8 fixing screws partway into the fixing holes at top and bottom of the lock. Tap the heads of the bolts downwards onto a surface and the outer rim of the lock will start to slide off the back. Remove this entirely and once off you can unscrew the two screws fixing the keypad to the panel.
3. Turn the keypad over and remove the 4 screws.
4. Lift off the covering panel carefully as there are 10 springs attached to this panel. Note that the red tumblers relate to the code shown above. Also note that the C tumbler is uncoloured and should not be removed.
5. To change the code hold the keypad with the code buttons down and depress & hold the C button (if this is not done you may damage some of the internal components). Reposition the tumblers to the new code (red tumblers are coded and blue tumblers are uncoded). Ensure that the square cut-out on each tumbler is facing the outside of the lock body, also ensure that the coloured mark is facing upwards. If any one tumbler is upside down or the wrong way round the lock will not work and if forced will break the internal components. The code must always start with a 'C'.

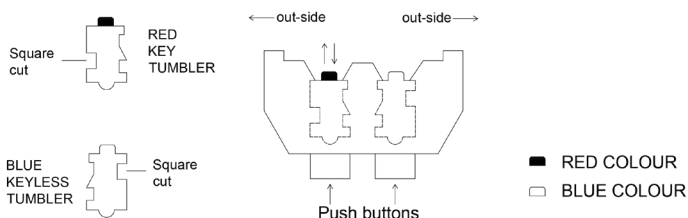

6. Replace the covering panel and tighten the 2 screws
7. The code is now changed, check to see that it is working correctly and make a note of the code for future reference. Once satisfied that the lock is working correctly refit keypads to the panel using the 2 screws and reassemble the lock.

MAINTENANCE

6 monthly:

1. Remove keypads from the lock.
2. Spray the inside of the lock thoroughly with WD40 or equivalent, through the tumbler holes at the back of the lock.
3. Spray all the fixing accessories and the latch with WD40 or equivalent.
4. Push each of the buttons and rotate the knob several times to make sure the lock is working smoothly.

 **GATEMASTER**

VISIT GATEMASTERLOCKS.COM FOR MORE INFORMATION

